

# Cubicon Style<sup>®</sup> (3DP-210F)

## Operation Manual





- **Please read the safety cautions carefully before using the product, and use the product appropriately.**
- **This document is provided to ensure the safety of users and to prevent property damage.**
- This device complies with part 15 of the FCC rules. Operation is subject to the condition that this Device does not cause harmful interference.
- The operation manual may be changed when necessary for a product upgrade.
- Please refer to the Cubicon homepage ([www.3dcubicon.com](http://www.3dcubicon.com)) to download this document.

## Table of Contents

1. Safety Caution.....	3
2. Directions for use .....	4
3. Introduction to Cubicon Style .....	5
4. Printer Parts and Accessories .....	9
4.1. Exterior of Printer.....	9
4.2. Interior of Printer and Heated bed .....	10
4.3. Internal structure of Extruder .....	11
4.4. Accessories .....	12
5. Installation .....	13
5.1. Unpacking.....	13
5.2. Installation of printer .....	14
5.2.1. Mounting of Clean Filter .....	14
5.2.2. Mounting of Filament Spool .....	15
5.2.3. Turn on printer power.....	16
6. How to use Printer .....	17
6.1. LCD and Operating Buttons .....	17
6.2. LCD Display of Status .....	17
6.2.1. Displaying the printer status on the LCD panel.....	17
6.2.2. Displaying the printer status with internal light color .....	18
6.3. Functional Menu during Printer Standby .....	19
6.4. Functional Menu during Printing.....	20
6.5. Caution and Notes on Using the Functional Menu .....	21
6.6. Replacing Filament (Loading/Unloading) .....	23
6.6.1. Loading Filament (Printer in Standby Mode) .....	23
6.6.2. Unloading Filament (Printer in Standby Mode) .....	25
6.7. Separating Extruder module (Mounting).....	27
6.8. Cleaning Printer.....	29
6.8.1. Cleaning for normal Auto Leveling .....	29
6.8.2. Cleaning of Heated Bed.....	30
6.8.3. Cleaning of Extruder .....	31
6.8.4. Replacement of Clean Filter.....	34
6.9. Firmware Update .....	34
7. Printing.....	35
7.1. Printing for the First Time .....	35
7.2. Printing after Replacing Filament .....	38
7.3. Replacing Filament during Printing.....	39
7.4. Supplying Filament after Filament Runs Out during Printing.....	40
8. Troubleshooting.....	41
9. Product Specifications.....	46

## Symbols used in the operation manual

	<b>Warning: Serious injury or property loss may result if the instruction is not followed.</b>
	<b>Caution: Minor injury or property damage may result if the instruction is not followed.</b>
	<b>Note: Indicates a useful tip or additional information.</b>
[ ]	This shows the buttons to be clicked.
{..>..}	This shows the tree structure in the LCD menu.

## 1. Safety Caution

Please read this 'Safety Caution' before using the printer and always follow the guideline provided.

This guideline is provided to ensure the safety of users, prevent the injury of third parties and prevent damage to the printer.

Failure to follow this guideline may lead to serious injuries or printer damage.



Since the printer generates a high level of heat during operation, there is the risk of burning if you place your finger or another part of your body or fixtures inside the printer during operation. Place the body part or fixtures only after the operation is terminated and the printer has been sufficiently cooled.

The printer has a number of moving parts, including the motor, belt and gear. There is the risk of injury or property damage from being trapped if a body part or fixtures are placed inside the printer during an operation.

Penetration of water or other liquids as well as the metal pieces or other conductive foreign substances inside the printer can cause fire or electric shock. Please take care to avoid operating the printer with wet hands, as this can cause fire or electric shock.

Select the installation site carefully to avoid causing injury to children or pets. Children or pets must be observed and protected carefully if they are near the printer.

The printer and its parts have sharp edges. Be careful to avoid injury or printer damage.

Since the filament used in the printer can cause fire or injury, do not heat it or deform it with another piece of equipment. Carefully handle the outputs and filament scraps, as swallowing them can cause suffocation, etc.

Never use a volatile substance with the printer, as it can cause a fire or explosion. In addition, remove ignition materials or flammable materials around the printer as they can cause fire.

The printer uses a high brightness LED for illumination. Do not look at it directly in order to protect your eyes.

Do not destroy or alter the printer's power cable or USB cable, and make sure that only the rated voltage is supplied.

To move the printer, stop the printer operation and disconnect the power cable and USB cable after the internal parts are sufficiently cooled and the printer is turned off.

Do not place a filament or object in an empty space inside the printer, as it can cause printer damage and fire.

Do not turn off the power while the heated bed or extruder is heated up. Because the cooling fan is not spinning the print may be broken down or fire may occur by high temperatures.



The cooling fan is not spinning equipment failure or fire may occur by high temperatures.

Do not install the printer outdoors or in a vibrating, humid or dusty area.

Do not install the printer in an unstable or uneven surface.

In addition, please take care to remove any object that may be damaged by the heat or vibration generated by the printer's operation.

If an unauthorized filament or part is used with the printer, it may damage the product and/or violate the conditions of the product warranty. Any problem caused as a result will not be covered by the warranty.

Do not disassemble or alter the printer except as specified in the Operation Manual, as it may cause the injury or printer damage. Any problem caused as a result will not be covered by the warranty.

Do not apply excessive force or impact to the printer, as it may cause injury or printer damage. Read the caution in the Operation Manual carefully before using the printer.

## 2. Directions for use

For proper printing, read “Directions for use” prior to the printing and comply with it.

<b>G-Code preparation</b>	G-code file is to be made using specific slicing software, so called Cubicreator (v2.5 and above) * Cubicreator must be set up for Cubicon Style (3DP-210F) Printer could be out of order if you set up software for other printers.
<b>Filament</b>	Please use the authorized filament which HyVISION SYSTEM provides. * It is excluded from warranty in case of the malfunction or damages caused by using 3rd party filament which are not approved for Cubicon. Please use the unsealed filament spool as soon as possible. Keep your filament tightly wound on the spool and sealed. * Using contaminated filament by humidity and dirty can cause the breakdown of printer and printing quality problem.
<b>Mounting and Dismounting of filament spool</b>	After mounting the filament considering the spool rotation/ insertion direction, turning the label of spool outward. Make sure if the filament is loosened on the spool during dismounting it.
<b>Replacement of Filament Loading &amp; Unloading</b>	Take notice of Extruder temperature setting. * If the extruder temperatures are not set properly, nozzle blockage and filament grinding can occur. When exchanging the filament, take notice of Extruder temperature setting and remove residues inside of nozzle
<b>Temperature condition of Extruder(Nozzle) And Heated bed</b>	Heat up the extruder (nozzle)/ heated bed to fit the proper temperature of filament. * The printing quality can be improved by configuration of optimal value acquired through user experience. In case the temperature of filament is out of proper temperature range, bad printing quality and breakdown of the printer such as carbonization, extruding failure, grinding, and warping. Remove the print object after the heated bed cools down accordingly.
<b>Extruder</b>	Regularly clean the Extruder. Open the cover of Extruder to remove the residue inside, contaminants of Gear, and filament path. * Pay attention not to damage the internal wire when opening the cover of extruder to clean inside.
<b>Cleaning of Extruder and Nozzle</b>	Regularly check the extrusion condition and clean it. * The replacement of worn out nozzles due to normal use is excluded from the warranty service. After heating up the Extruder and clean the external nozzle of Extruder with pure cotton cloth. * Clean the nozzle tips because its carbonized residue of filament may cause the error of tilt align. Pay attention not to damage the Extruder when cleaning the internal nozzle using Nozzle Management Pin. * Extruder failure can occur by improper use, so thoroughly become skilled. Do not repeat cooling and heating while the filament remains inside of the nozzle.
<b>Separating/ Mounting of the Extruder Module</b>	Be sure to turn off the power when separating or mounting the Extruder. Do not power down when the Extruder is heating up. * It causes the damage to the internal circuitry because fan is not working.
<b>Cleaning the heated bed</b>	Make sure not to get any contaminants at the 3 ground connection points on the heated bed before Auto tilting. * If the filament residue remains at the 3 ground connection points where calibrate the tilting, it may cause the tilt align error. Please make sure to clean the 3 ground connection points before printing. Clean the contaminants with scraper or dried cotton cloth. * The replacement of damaged heated bed such as peeling off of the coated bed due to normal wear and tear is excluded from the warranty service. Use the high purity acetone or water to clean the contaminated heated bed. * Do not use wet wipes because washing ingredient of some wet wipes can contaminate the coating of heated bed.
<b>Auto tilt</b>	In case of Auto tilting failure, check if the nozzle touches the 3 ground connection points and re-try the tilting after cleaning the heated bed and nozzle tip. With the continuous error, please contact the official CS team to check and repair it.
<b>Preparation of AS request</b>	Take a picture or video record the malfunction status of inside of the printer or LCD Display. * Users need to clarify the situation as much as possible to proceed the repair service.

### 3. Introduction to Cubicon Style

#### Operation

##### What is Cubicon Style?

Cubicon Style is an FFF (Fused Filament Fabrication) type 3D printer that controls the position of an extruder with an x/y/z axis controlling motor, uses a heating system to melt the filament supplied to the extruder, pushes the melted filament outside the nozzle with the extruder motor, and constructs a printed object layer by layer.

Cubicon Style greatly improves print stability by adding user-friendly and innovative functions.

#### In-house designed Extruder module



The most important and key part of an FFF(Fused Filament Fabrication) type printer is the extruder, which heats and melts the filament and then pushes it out of the nozzle.

**Cubicon Style** features in-house designed module type extruder, the first of its kind in Korea. Using the module type extruder maximizes the user friendliness, as the extruder can be easily removed from the printer for service by unscrewing the bolts and cable when the nozzle is clogged.

### Stylish Design / Easy control with Touch button



**Cubicon Style** is designed to be ideal for being equipped on the desk at home, educational place and offices. The control panel is applied with the LED display with Touch button to enhance the usability and elegance. Also, the menu key is arranged according to the most usable functions, being able to operate without any difficulty for the novice.

### Clean Filter to ensure user's Health and Filter fan control

The filament material used by the FFF type printer is known to be harmless to the human body. However, dusts and impurities can be generated when it is melted by heat.



**Cubicon Style** uses a deodorizing filter, HEPA filter and Purafil catalyst to improve the filter performance.

- > HEPA filter: 13H grade to collect 99.97% of 0.3um particulate matter.
- > Deodorizing filter: Filtering of harmful gas.
- > Purafil catalyst: Filtering of organic compounds generated by copiers and printers.

Source	Gases Removed	Purafil	Activated carbon
Automobile Exhaust Gas	Hydrocarbons	○	
	Hydrogen sulfide	○	○
	Nitric oxides	○	
Effluent from Living Body	Organic acids	○	○
	Oxides of sulfur	○	
Cleaning Product	Ammonia	○	
Copier/Printer	Ozone	○	
	Volatile Organic Compounds	○	
Discharge Gas from Industrial Complex	Acrolein	○	
	Hydrocarbons	○	
	Hydrogen sulfide	○	
Office Furniture	Aldehydes	○	○
	Formaldehyde	○	

[Comparison of Filtering of Activated Carbon and Purafil Catalyst]

Also, the **Cubicon Style** has the enclosed build area and automatically controls the constant ambient temperature.

It ensures the pleasant and constant printing environment for users.

### Auto Leveling Plus Function

The flatness and distance from the nozzle of the heating bed, which is the platform on which the printed object is constructed, are important factors determining the quality of the printed object. The conventional FFF printer not fully auto levels, as the user must manually or semi-manually adjust the bed height, or even when it claims to be auto level, it was not fully auto level since the deviation is calculated with the software and reflected in printing.

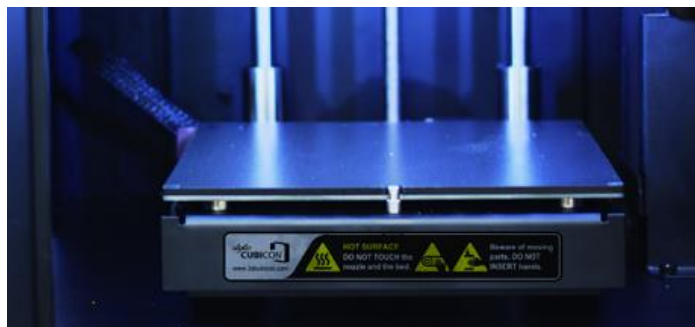

**Cubicon Style** features the unique Auto Leveling Plus function, which precisely measures the height of the heated bed and uses it to adjust the space from the nozzle in optimal condition. Moreover, it is applied with a special coating on the heated bed to eliminate the inconvenience of having to use the Kapton tape, and thus ensures an optimum print quality and minimum maintenance.

**Experience Cubicon Style's unique Auto Leveling Plus function.**

## Use of Diverse and Smart Materials

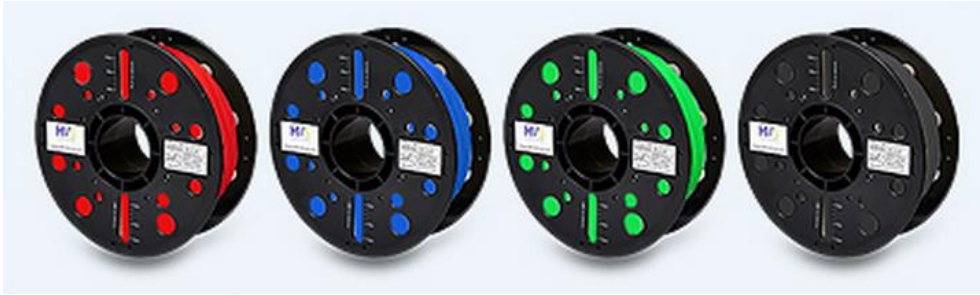

**Cubicon Style** supports the use of both PLA and ABS, which are mostly used by the individuals, as well as Flexible filament without adding any extra equipment or exchanging of the extruder. Explore the joy of printing various printed object with diverse materials.

## Self-diagnosis feature



Most FFF-Type 3D Printer is heated up at high temperature and cools down the heating with the fan. Therefore, the malfunction of heater or fan may cause the problem to the printing quality and safety. **Cubicon Style** has the self-diagnosis feature alerting the defect of heater and fan to take a proper action. It enables user to use the printer more safely.

## Quiet Printing



Most of 3D printer cannot be free from noise due to being driven by motor and belts.

**Cubicon Style** has enhanced the noise level by reducing more than 10dB noise than previous model.



## 4. Printer Parts and Accessories



The printer is packaged after a total test of output conditions. This testing may leave traces of usage on the heating bed, nozzle, etc. Be assured that these are traces of testing, and that there is no problem with the product.

### 4.1. Exterior of Printer

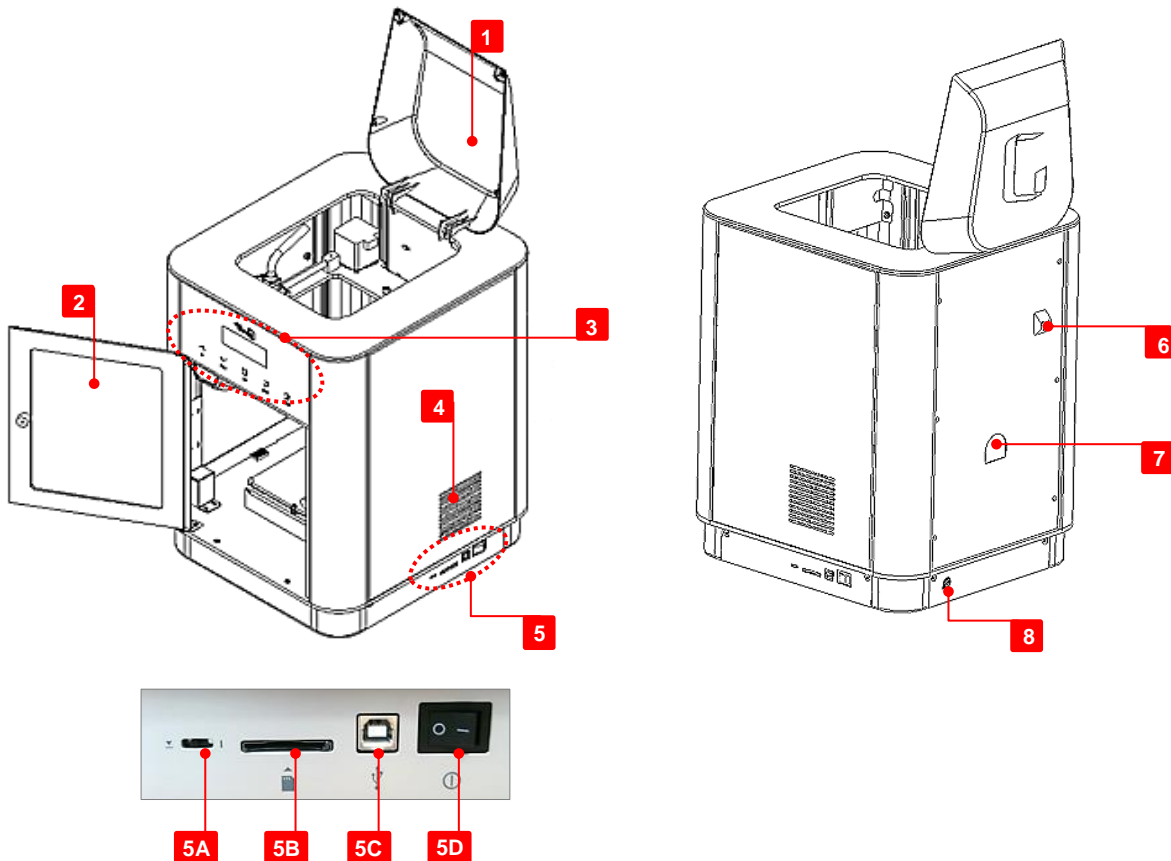

[1] Top door	Used for maintenance such as the filament replacement (loading / unloading)
[2] Front door	Used to pull out the molded part
[3] LCD and operating buttons	LCD screen and touch buttons to operate printer
[4] Vent for filter fan	Internal air vent while filter fan operates.
[5] Interface part	Interface and power button.
[5A] Firmware switch	Switch for updating the firmware of printer.
[5B] SD Memory slot	Slot to insert SD Memory card.
[5C] USB input (Type-B)	USB input terminal to connect to a PC
[5D] Power switch	Power switch for the printer.
[6] Filament insertion hole	Hole to feed the filament into the printer.
[7] Spool holder mounting hole	Hole to hang the filament spool holder.
[8] Power input	Terminal to connect the cable of DC power adapter

## 4.2. Interior of Printer and Heated bed

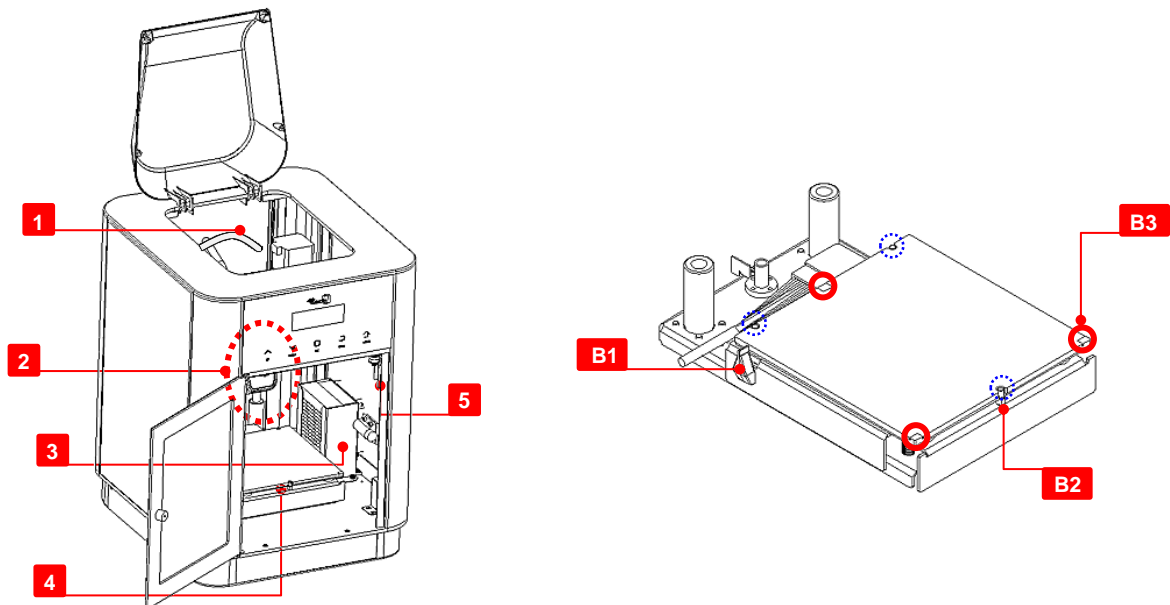

[1] Teflon tube	Path to feed the filament into the Extruder. (Be cautious not to bend it)
[2] Extruder	The part to move and extrude the molten filament.
[3] Clean filter case	The part to mount the clean air filter.
[4] Heated Bed	Bed platform to print out the object.
[5] Internal LED ambient light	LED light to show the internal status of the printer.
<b>Heated Bed</b>	
[B1] Nozzle cleaning brush	Brush to clean the nozzle end at the beginning of the printing. (Heat resistant rubber)
[B2] Bed position fixing Pin (3 spots)	Pin to position of heated bed. <b>* Please make sure the pin is mounted at 3 spots on the bed.</b>
[B3] ground connection points (3 spots)	Point to check the bed leveling. (Uncoated 3 spots) <b>* Please keep these 3 spots clean because Auto Leveling fails with the contaminants on 3 spots.</b>



**Do not touch the nozzle of extruder and heated bed being heated up while printing.**

### 4.3. Internal structure of Extruder

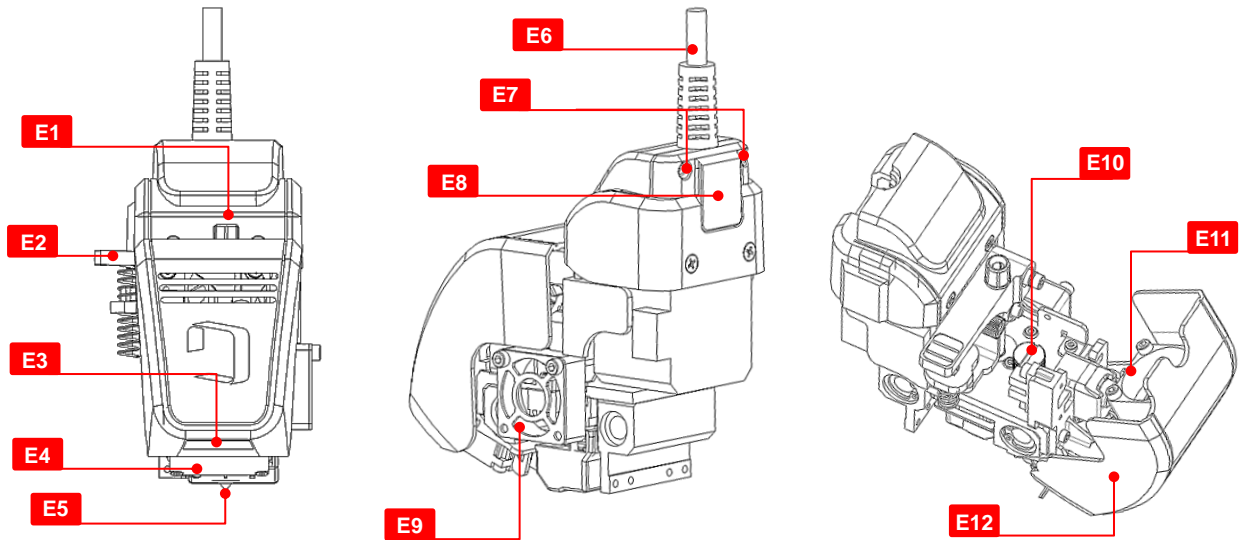

[E1] Filament insertion hole	Hole to insert the filament into the Extruder through Teflon tube.
[E2] Filament handle	Handle to manually pull the filament out of the extruder or insert it.
[E3] Mold fan	Fan to flow the air into the molded object.
[E4] Heated block cover	Cover case to surround the nozzle heated block. (heat-resisting rubber)
[E5] Nozzle	Nozzle to extrude the molten filament.
[E6] Extruder cable	Cable for power supply of Extruder and signal transfer
[E7] Cable fixing screw	Screw to fix the cable to the Extruder (m2.5)
[E8] Cable fixing block	Block to fix the cable to the Extruder.
[E9] Cool End fan	Fan to cool down the heated block.
[E10] Extruder module fixing screw	Fixing screw to separate the Extruder module.
[E11] Gear fan	Fan to cool down the gear of internal Extruder.
[E12] Extruder cover	Cover to check the internal Extruder



- \* Do not touch the nozzle of extruder being heated while printing.
- \* Verify if there is some obstacles under the extruder when opening the Extruder cover.
- \* Remove or mount the Extruder module when the nozzle temperature cools down and power turns off.

## 4.4. Accessories



### Tweezers (x1)

Used to remove foreign substances, such as filament residues



### AC/DC Adapter, Cable (x1)

Power supply adapter and cable.



### Scraper (x1)

Used to separate the molded part or remove foreign substances from the heating bed.



### USB Cable Type-A/Type-B (x1)

Used to print through the connection of PC and printer.



### Antistatic brush (x1)

Used to remove the pollutants such as the filament residues.



### Clean filter (x1)

Mounted into the clean filter case.



### Nozzle pin $\Phi = 1.5\text{mm}$ (x1)

Used to clean inside of the nozzle when the output quality has deteriorated due to a polluted nozzle.



### Filament spool (x1)

Mounted in the spool carrier. A filament spool is provided to PLA or ABS with random color.



### Wrench 2mm (x1)

To unscrew the bolts of cable fixing block when separating the Extruder module.



### SD Memory (x1)

Stores the G-Code file extension (\*.hvs) of 3D models for printing object.



### Spool holder (x1)

Used to mount the filament spool into the hole of rear printer.

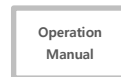

### Quick Start Guide / Operation Manual

Included as a printout or a file in the SD memory.



- \* The filament spool and clean filter are not mounted in the printer, but are packaged separately.
- \* The type and specification of the accessories included in the part may be changed without notice to enhance the product.
- \* Please use the Cubicon homepage or contact a distributor to purchase additional accessories.



**Using an unauthorized filament or part may cause damage to the product. Any problem related to the use of an unauthorized part will not be covered by the after-sales service. Always use accessories supplied by Cubicon.**



**Please use the specified Adapter. It may cause the considerable damage on the printer when using unspecified power supply to affect the injury or property loss.**

## 5. Installation



Be careful when unpacking and installing the product, as excessive force or ripping can damage the content.

### 5.1. Unpacking



Pay attention not to damage the Drive cable of extruder or Teflon tube being pulled, bent, stabbed to affect the operation of extruder and filament feeding.

- ① Place the package on the floor and remove the side packing materials including the accessories.  
Pay attention not to drop the packing materials including the accessories.



- ② Pull the product out of the vinyl bag and move to its installation place.  
Hold the product and take it out of the box. Holding the vinyl and taking it out will damage the product.

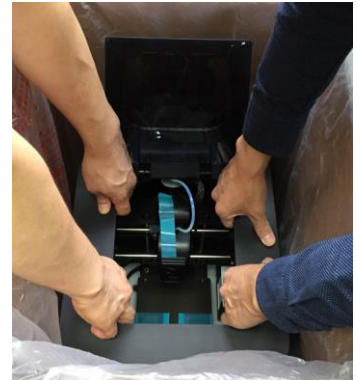

- ③ Remove the inside and outside tape.

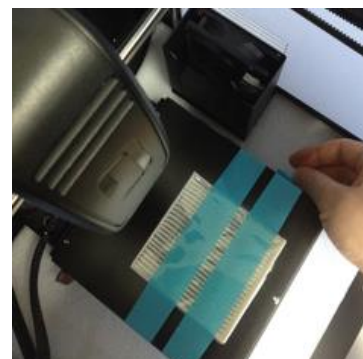

- ④ Remove the Cable tie of Extruder – Cut two side cable ties of Extruder with scissors.

Pay attention not to damage the drive belt when cutting the cable tie.

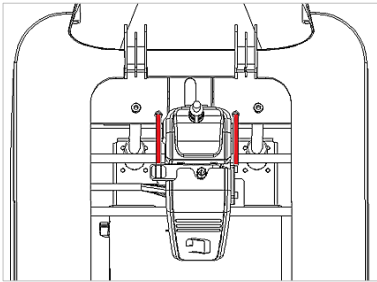

Remove red colored two cable ties in figure.

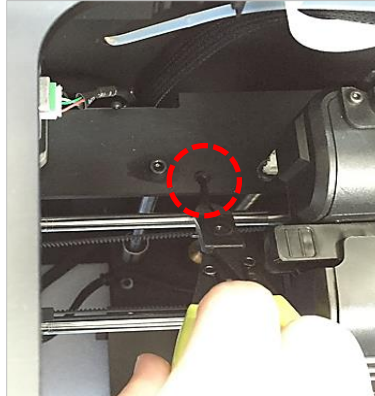

- ⑤ Remove the bottom package on the heated bed.

Lift the heated Bed up and remove the package.

If the heated bed cannot be lifted up manually, turn on the power and go to menu to activate {Motions>Bed Up}.



It may cause the failure of printer when the Cable Tie, tape and packaging is not removed. Please remove all fixed materials to operate the printer properly.

## 5.2. Installation of printer

### 5.2.1. Mounting of Clean Filter

Remove the package of included clean filter and mount it into the filter case at the internal right of printer.

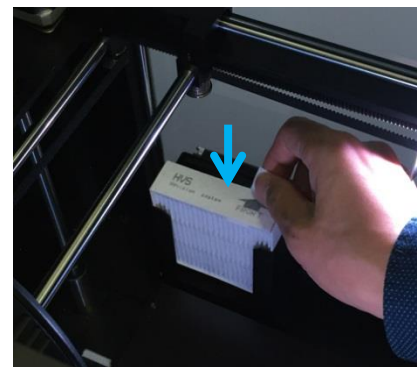
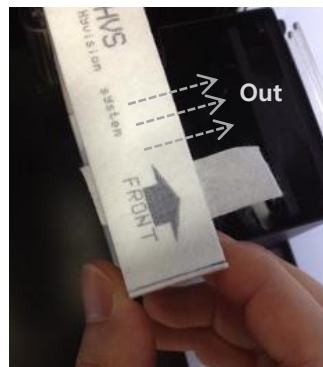

Mount the clean filter into the case in the correct position(The arrow should be outward)  
If it is positioned incorrectly, the filter performance will be degraded and cause a malfunction of the ventilation fan.

### 5.2.2. Mounting of Filament Spool

- ① Prepare the filament spool to be used.  
Cut off the filament fixing tape and remove the bent filament.



- ② Insert the spool holder into the hole at the rear of printer.  
Please be careful not to be fallen out of the spool holder.



- ③ Mount the filament spool into the spool holder and feed the filament into the insertion hole.  
**Be careful of the spool rotation/insertion direction.**

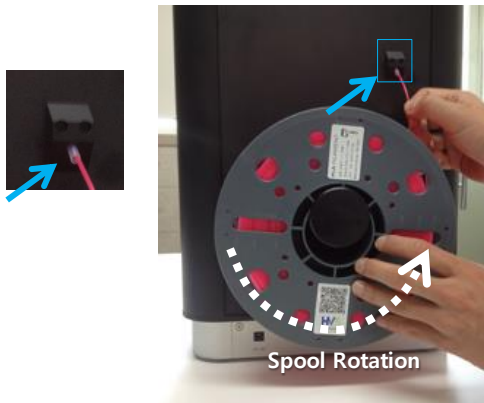

- ④ Open the top door and push the filament all the way into the printer body so that the filament is out of the Teflon tube.  
**Be careful not to bend, cut or twist the filament tube.**  
This may prevent the filament from being supplied properly.



- \* **Filament spool should be mounted in the correct direction. Please mount the spool with the company logo and sticker faced outward. It is designed in a way that filament spool should be fed rotating in counter clockwise. It may cause the feeding problem if the spool is mounted in the wrong direction. Please make sure that spool is mounted correctly before printing.**
- \* **When mounting the filament spool, any jamming object between filament spool holder and spool can cause malfunction. Remove any jamming object for smooth supply of spool when mounting the spool into the holder.**
- \* **Teflon tube is the path from filament spool to extruder. The length of teflon tube is optimized according to the printer, excessive force to pull the tube may cause deformation of the tube causing failure in feeding filament. Do not bend, cut or pull out the mounted teflon tube.**



- \* **Pay attention filament being unwound from the filament spool left when removing the filament spool from the spool holder. Tie up the filament left into the filament spool while storing the filament. When you take out the leftover filament from filament holder, make sure not filament not get loose and also wind filament tightly to the spool, otherwise feeding will not be smooth.**
- \* **Keep the leftover filament tightly wound up to prevent any dusts and moisture. Once filament is open for use, please try to consume it quickly. Long exposure to the outside environment can cause bad print quality or miscontact to the bed, in severe cases, clogging from nozzle, due to the moistures.**

### 5.2.3. Turn on printer power

- ① Switch off the power by pressing off button located behind the printer.



- ② Insert power cable to power source located on the back of the printer, and neatly arrange the cables and then hook up the power cable from the power adaptor to the power source.



Please make sure to check the following items before turning the power on.

- 1) Any cable twist, bending issues in connection to power source.
- 2) loaded state of filament spool/direction of rotation
- 3) Teflon tube is not interfered.
- 4) Check the condition of the Extruder cable as during unpacking, any cable damages related to connection of the extruder.
- 5) Check the state of the extruder module installation.  
During transportation, there could be loose screws of extruder module.
- 6) Check whether heated bed is at exact location. It could have moved and be at wrong position due to vibration during transportation.
- 7) Any damaged parts.
- 8) Any residue of package.

- ③ Turn on the power by pressing switch located behind the printer.



- ④ Check the LCD screen.

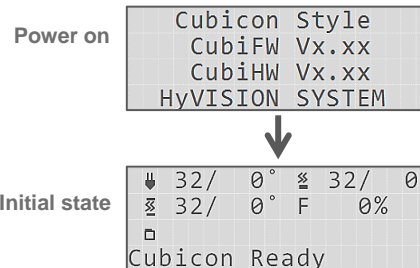

\*Number changes according to ambient temperature



- \* In case power and USB cable are separated, do not pull the cable, just pull the connector.
- \* USB cable is connected to PC to print directly from PC source or to get firmware updates. USB cable does not need to be connected at all times where PC is not required.
- \* Once powered on, main components regarding heating components will be checked up automatically.

If "Cubicon Ready" becomes "Check SelfTestResult", it is an indication that there could be an error in main component inside printer. When this happens, please do not start the operation of the printer until you make sure to check the components indicated as fail in Function Menu {Configuration>SelfTest Result}. In case that self-remedy seem difficult, please contact nearest After Service Center.



Do not turn off the printer with temperature of the Extruder still heated. When cooling fan does not move because power is off, it could damage the electronic components inside the printer, eventually damaging the printer.



## 6. How to use Printer

### Emergency Stop

When there is an error occurred when operating the printer, you can stop immediately by pressing power-off button located on bottom right corner.

### 6.1. LCD and Operating Buttons

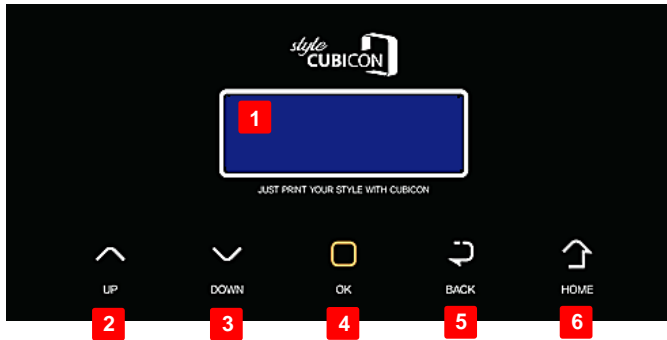

[1] LCD	It shows the current status of printer or menu.
[2] UP	Menu's position moving.
[3] DOWN	Menu's position moving.
[4] OK	Menu's selection.
[5] BACK	Go back to previous menu.
[6] HOME	Go to Home Menu.

### 6.2. LCD Display of Status



Current state of the printer is normally displayed through LCD or Internal light color.

#### 6.2.1. Displaying the printer status on the LCD panel

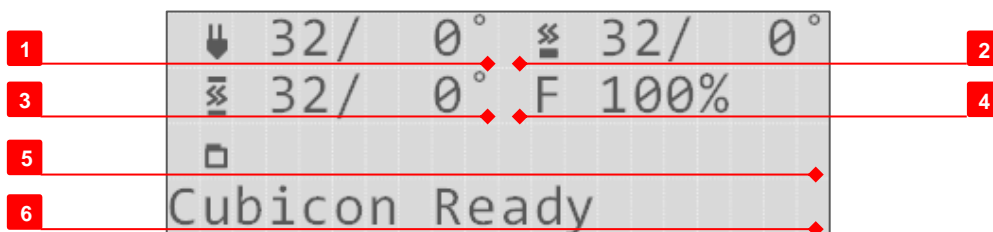
In case functional menu is not working (Home display), the current status of printer is displayed.



[1] Nozzle temperatures.	Current temperature/target temperature
[2] Temperature of heated bed.	Current temperature/target temperature
[3] Temperature inside printer.	Current temperature/target temperature
[4] Cooling Fan RPM	FAN RPM (Max 100%)
[5] Selected file name	Name of the selected file from SD Card.
[6] Printer operation status.	Current status of printer. When it is being printed, it displays duration of printing (hh:mm), progress [time left]".

	<ul style="list-style-type: none"> <li>* The extruder nozzle and heated bed are heated or cooled to achieve the target temperature.</li> <li>* The printer's internal temperature rises with the heat from the nozzle and heated bed when the printing begins. Once the current temperature reaches the target temperature, the outside air is circulated to cool the printer.</li> <li>* To ensure safety, this product does not use a separate heater to increase the current temperature.</li> <li>* The noise from the ventilation fan is generated when the convection circulation function is activated to lower the inside temperature.</li> <li>* The unit of temperature is '°C'.</li> <li>* When the printing is paused, the file name and printing time are displayed on [5].</li> <li>* Remaining printing time will differ from the estimated time of slicing program and type of model. It may automatically renew the remaining printing time during printing process.</li> <li>* The details of the LCD display may be different according to the firmware version.</li> </ul>
	<ul style="list-style-type: none"> <li>* For the filament, the target temperatures (heated temperatures) of the [1] extruder and [2] heated bed are very important.</li> <li>[1] If the extruder nozzle temperature is too far above or below the filament melting temperature, extrusion quality can be poor, and an extruder malfunction may result. <b>The recommended filament melting temperature ([1] Extruder target temperature) is printed on the sticker of the filament spool. Make sure that the printer is maintained at the proper temperature, by referring to the target temperature.</b></li> <li>[2] The heated bed temperature also differs according to the type of filament used. <b>The recommended heated bed temperature for Cubicon Style is 60~70 for PLA/Flexible and 110~120 for ABS. However, as the actual temperature may differ according to the printed object, use the proper temperature accordingly. If the heated bed temperature is not suitable for the filament being used, the printed object may not adhere to the heated bed or the bottom output status may be defective.</b> Cubicon Style's heated bed is designed to ensure that the printed object is adhered to the heated bed when printing at a specific temperature or higher in the case of PLA/ABS filament even without the Kapton tape, as well as to ensure that the printed object is easily removed from the bed when the temperature drops.</li> </ul>

### 6.2.2. Displaying the printer status with internal light color

Cubicon Style has built-in LED lights in front of the machine to check the interior of printer.

It enables to check the current printer status through the LED color, which changes to different color according to the printer status.

Status	Color	Explanation
Booting / Self- diagnosis	R/G/B	When power on or while self-diagnosis
Stand-by	C	Stand-by status of operating printer
Sleep mode	G	Non-operation of printer or no activation of user commend for a while.
Heating	Y/C	During heating up the temp of heated bed, and Extruder nozzle.
Printing/Leveling	W	During Auto Leveling process or printing with the running gear.
Pause	W/Y	When activating Pause function while printing.
Termination of printing	Y/C	Printing is terminated.
Error	R/M	To require the user's inspection when problem occurs.

	<ul style="list-style-type: none"> <li>* A key to abbreviations of color W(White), R(Red), G(Green), B(Blue), C(Cyan), Y(Yellow), M(Magenta)</li> <li>* If there are two colors at a status, it means cross-luminosity.</li> </ul>
---	--

### 6.3. Functional Menu during Printer Standby

If [6.2.1. Displaying the printer status on the LCD panel](#) is shown on the LCD screen of Cubicon Style, press the [OK] button to display the functional menu. You can access each item of the function menu by pressing [OK], [UP], [DOWN], [BACK] button. Press the [HOME] button to return to the status display window.

The following menu is available when the printer is in standby mode. A different menu is displayed when the printer is in printing mode.

> SD Card	Selects the output file in the inserted SD memory.
> Prepare	<b>Preparation for printing</b>
> Preheat	The heated bed and extruder nozzle are preheated to the set temperature
> ABS / PLA / U01 / U02	They are preheated according to each preset temperature.
> Load Filament	This inserts a new filament into the extruder.
> Temp	This sets the extruder nozzle temperature to use a new filament.
> Load Start	This inserts the filament into the filament entry when the target nozzle temperature is reached.
> Unload Filament	This removes the filament in the extruder.
> Temp	This sets the extruder nozzle temperature to remove the filament.
> Unload Start	This pulls out the filament when the target nozzle temperature is reached.
> Temperature	<b>Printer operating temperature control</b>
> Cooldown	Temperature initialization (Heating is stopped to lower the temperature)
> Extruder	Extruder nozzle temperature setting
> Bed	Heated bed temperature setting
> Chamber	Printer inside maximum temperature setting
> Fan speed	Print fan speed setting
> Motions	<b>Printer movement control in standby mode</b>
> Disable stepper	This disables the motor to enable manual control.
> Bed Up	The heated bed is lifted.
> Bed Down	The heated bed is lowered.
> Extr. Move	The extruder motor is manually rotated (manual lifting or lowering of the filament).
> Home	The X/Y (extruder) and Z (heating bed) are moved to the zero position.
> Parking	They are moved to the position (rear center) for easy maintenance.
> Configuration	<b>Default setting</b>
> SelfTest Result	Display the test or inspection information of Nozzle heater& Temp sensor, Bed heater& Temp sensor, and Fan.
> Test Again	Manually operate Self-Test
> Preheat Temp	This sets the preheat temperature.
> ABS / PLA / U01 / U02 Preheat Temp	This sets the preheat temperature according to each condition.
> Extruder	Extruder nozzle preheat temperature setting
> Bed	Heated bed preheat temperature setting
> Chamber	Printer inside maximum temperature setting
> Auto Leveling	This adjusts Auto Leveling.
> OFFSET	Offset between heated bed and nozzle after Auto Leveling.
> Filter Fan	Filter fan operation setting.
> Baudrate	This sets the communication speed when printing through USB connection from PC.
> 250000 / 115200	Default 250000, Printing through PC connection(MAC OS) 115200

> Store to EEPROM	The changed settings are saved in EEPROM. When reboot without saving the changed setting, it cannot apply the changed setting value.
> Initialize EEPROM	The settings are initialized.
> Information	This displays the equipment model name and firmware/hardware version.

Note) The actual menu structure may differ depending on the firmware version.  
This document is based on Firmware v1.0.1, Cubicreator v2.5.

## 6.4. Functional Menu during Printing

A different functional menu is displayed when the [OK] button is pressed while the printer is printing an object. To prevent problems related to user error, only the applicable menus such as print suspension are displayed.

You can access each item in the function menus by pressing the [OK], [UP], [DOWN], and [BACK] button. Press the [HOME] button to return to the status display window.

Refer to the following table for the description of each functional menu item.

> Temperature	<b>Printer operation temperature control.</b>
> Extruder	Extruder nozzle temperature setting
> Bed	Heated bed temperature setting
> Chamber	Printer inside maximum temperature setting
> Fan speed	Mold fan speed setting
> Pause Print	<b>Printing is temporarily stopped.</b>
> Continue Print	Printing is continued.
> Load Filament	A new filament is inserted into the extruder.
> Temp	This sets the extruder nozzle temperature to use a new filament.
> Load Start	This inserts the filament into the filament entry when the target nozzle
> Unload Filament	This removes the filament from the extruder.
> Temp	This sets the extruder nozzle temperature to remove the filament.
> Unload Start	This pulls out the filament when the target nozzle temperature is
> Stop Print	This completely stops printing after a job is paused.
> Stop Print No/Yes	Stop printing confirmation
> Stop Print	<b>Printing is completely stopped.</b>
> Stop Print No/Yes	To confirm the current printing process to be stopped.
> Configuration	<b>Basic setting</b>
> Filter Fan	Filter fan operation setting
> Information	Displays the equipment model name and firmware/hardware version.

Note) The actual menu structure may differ depending on the firmware version.  
It may also be different if the printing is controlled by a PC over the USB connection.  
This document is based on Firmware Ver. 1.0.1, Cubicreator v2.5.



	<b>When the Pause or Stop function is selected during printing, there will be a slight time delay. This is due to the process of printing data that are already in the buffer memory. Printing will be paused or stopped after a brief delay.</b>
---	---







## 6.5. Caution and Notes on Using the Functional Menu

Cubicon Style contains a motor and a heating unit, and the printer functions are interconnected with these parts.

Inappropriately combining these functions may cause printer damage or injury.

Please remember the following cautions and notes when you use the product.

<p>{SD Card}</p>	<ul style="list-style-type: none"> <li>- Cubicon Style can print a 3D model file using a G-Code file (*.hvs) created by the slicing program Cubicreator. The printer will not recognize files in other formats.</li> <li>- Use the dedicated software Cubicreator to create G-Code files for the printer. G-Code files created by other slicing software program cannot compatible to the Cubicon.</li> <li>- Regarding equipment setting through Cubicreator, select 'Cubicon Style (3DP-210F)'. If set to other equipment, it may cause the problem on printed object.</li> <li>- Because the file name in the SD Card is recognized in English only, save normal G-Code file name in English.</li> <li>- Files in the SD Card will be shown on the screen from the latest sorted files.</li> <li>- The number of Files in the SD Card is limited up to 150 per each folder. Clean up the folder because it is not shown if there are more than 150 files in the folder.</li> <li>- Folder of the SD Card will be recognized up to step# 2 Sub- folder. In other words, it is recognized as Root / Sub1 / Sub2.</li> </ul>	
<p>{Preheat} and {Temperature}</p>	<p>The extruder nozzle and heated bed must be preheated according to the filament being used in order to properly print the model Although the extruder nozzle and heated bed are automatically preheated to the temperature set in G-Code before printing an object using a G-Code file, the user can manually preheat the nozzle and heated bed using the {Preheat} and {Temperature} settings.</p> <p>{Preheat} raises the temperature of the nozzle and heated bed to the preset temperature according to the ABS or PLA material. {Temperature} is used to separately adjust the nozzle temperature, heated bed temperature, convection circulation temperature, and print fan speed.</p>	
<p>Temperature setting of {Extruder} =Nozzle temperature</p>		<p><b>When printing with G-Code, the temperatures of the heated bed and nozzle are sequentially raised to the values set in G-Code. Therefore, the target temperature of the extruder nozzle is displayed as "Wait" when the temperature of the heated bed is not at the target temperature.</b></p>
<p>Temperature setting of {Heat Bed}</p>		<p><b>If the extruder nozzle is not heated or is heated to a temperature lower than the filament melting temperature, the filament may be fragmented or cut off, or in extreme cases the extruder may malfunction.</b></p>

		<ul style="list-style-type: none"> <li>* Printing will begin when the heated bed is heated to the temperature set in the G-Code.</li> <li>* The 'bottom structure' option can be applied when G-Code is saved by Cubicreator if the printed object does not adhere to the bottom even after adjusting the temperature of the heated bed.</li> <li>* Temperature setting range of heated bed is 50 ~ 120C. In the case of less than 50C it is shown in 0C which means a temperature of heated bed does not heated the heating bed.</li> </ul>
Temperature setting of {Chamber}	The chamber controls the internal ambient temperature of the printer. If the internal temperature is higher than the set point of temperature, it operates the filter fan to cool the printer down to the target temperature.	
		<ul style="list-style-type: none"> <li>* The temperature setting range of Chamber is 30 ~ 55C. If less than 30C, it will be shown as 0C meaning that the internal cooling fan is not operating.</li> <li>* Cubicon Style cools the inside with the external air, please note if temperature of chamber is set to 0C, the internal temperature will be increased because the cooling fan is not working.</li> <li>* The internal temperature cannot go down to setting temperature according to the external air because the Cubicon Style cools down the inside with the outside air.</li> </ul>
{Load/Unload Filament}	Load/Unload Filament operates the extruder motor to move the filament after the extruder nozzle temperature reaches the set temperature. Check the extruder temperature when you load or unload the filament.	
		<p><b>Load/Unload is generally used to replace the filament.</b></p> <p>To replace a filament, it is recommended to preheat the extruder nozzle in advance by setting the extruder temperature to the extruder nozzle temperature of the filament already melted in the nozzle or that of the new filament, whichever value is higher.</p>
		<p><b>When a filament is used up, the edge of the filament will remain inside the extruder. Using the printer without removing the residual filament may cause an extruder problem. Unload the filament using {Unloading} after a filament is used up to remove the filament remaining inside the extruder.</b></p>
{Motions}	<p>{Motion} provides the X/Y/Z axis operation mostly for maintenance. When you use this function, make sure that there is no object or body part in the intended destination.</p> <p>The {Motion} function performs an abnormal printer function. It is recommended not to use the function during normal time.</p>	
		<ul style="list-style-type: none"> <li>* It should be noted that if there is a body part or object in the path of {Motions}, injury or damage may result. In particular, the printed object should not be left inside the printer after printing is completed, as it may be collided with during {Motions}.</li> <li>* When executing {Ext. Move} while the detachable extruder part is mounted, the extruder temperature should first be increased above the level required to melt the filament in use. Otherwise, the filament may be fragmented or cut off, and in extreme cases the extruder may malfunction.</li> </ul>
{Auto Leveling Offset}	<p>It enables to manually adjust the distance between nozzle and heated bed through {Configuration&gt;Auto Leveling}&gt;OFFSET}. However, the Cubicon Style automatically measures the height and adjusts it.</p> <p>Therefore, please set Offset at "0" in case of normal operation.</p> <p>The '-' value of offset to make closer the distance between nozzle and heated bed, '+' value to make the distance far-off.</p>	
		<p><b>When tilting process fails, clean the carbonized filament at the top of nozzle and level point on the bed plate. If the issue continues, please contact the authorized AS center to fix it.</b></p>

## 6.6. Replacing Filament (Loading/Unloading)

Filament must be inserted into the extruder to push the melted filament, which is the printing material, through the nozzles, and the filament must be pulled out of the extruder to replace a filament with another.

Loading is the process of inserting the filament into the extruder when there is no filament inside the extruder so that the filament can be melted and pushed out of the nozzles for printing, while unloading is taking the filament out of the extruder.

To replace the currently used filament with another filament, the current filament must be unloaded and the new filament must be loaded.

### 6.6.1. Loading Filament (Printer in Standby Mode)

- ① Pull out the filament to the edge of the Teflon tube, referring to [“5.2.2. Mounting of Filament Spool”](#)



- ② (While the power is on)  
Select {Prepare > Load Filament} from the menu.

```
SD Card      →
>Prepare    →
  Temperature →
  Motions    →
```



You can click 'Temp' and set or change the target temperature to load. Set the temperature to suit the filament in use.

```
Preheat
>Load Filament
  Unload Filament
```

The figure on the right shows the heated bed temperature changed to 240oC.



The “Wait...” message will blink until the extruder nozzle temperature reaches the target level.

```
*Temp : ↓134/240°
  Wait...
```

- ③ When the extruder nozzle temperature reaches the target value, the “Wait...” message disappears, and the {Load Start} menu is displayed.

```
Temp : ↓240/240°
>Load Start
```

When you select {Load Start}, the extruder motor to move the filament is operated, and “Loading” gets started after home sensing.

```
Loading...
Wait...
```

**If the edge of the filament in the Teflon tube is bent or pressed, cut off the part with scissors**

When stopping the movement of extruder, hold the filament and push it until you can feel it is pulled to the filament entry at the top of the extruder.

If you insert the filament by around 3cm, the filament is notched to the gear and automatically pushed.

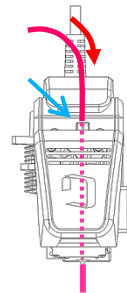

When the filament is pushed automatically, wait for a while until the melted filament sticks out of the nozzle at the bottom. Press the [OK] button to stop loading after around 30cm of filament slides down.

```
Loading...
Touch OK Button
To Load Stop
```

- ④ Insert the edge of the Teflon tube into the filament entry. Remove the filament sticking out of the nozzle with tweezers or another appropriate means.

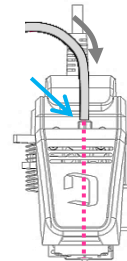

- \* **Make sure that no part of the body contacts the nozzle area, as both the nozzle and the filament are hot when the extruder nozzle temperature is raised.**
- \* **The filament may be stuck at the entry of the nozzle rod when it is pushed into the nozzle rod of the detachable extruder part. (A cracking sound may be produced.) In that case, press the filament handle and pull out the filament. Cut off the edge with scissors and insert it into the filament entry to attempt loading again.**
- \* **When manually operating the handle, be careful not to pull out the filament with excessive force, as it may damage the internal sensor or nozzle rod.**



**The filament is coiled around the spool. Because of its shape, the filament that is unwound from the spool will have a gentle curved shape. When this curved shape is inserted into the extruder, it may not be smoothly pushed into the entry of the nozzle rod. It will be easier if the filament is positioned so that it is curved in the clockwise from the front.**

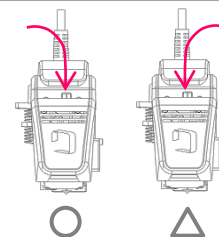



### 6.6.2. Unloading Filament (Printer in Standby Mode)

- ① Pull the Teflon tube out of the filament entry of the extruder.

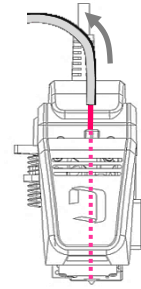

- ② (While the power is on)  
Select {Prepare > Unload Filament} from the menu.

You can click {Temp} and set or change the target temperature to unload. Set the temperature to suit the filament in use.

The figure on the right hand side shows the heated bed temperature changed to 240oC.

“Wait...” blinks until the extruder nozzle temperature reaches the target level. Wait until the nozzle temperature reaches the target value.

When the extruder nozzle temperature reaches the target value, the “Wait...” message disappears, and {Unload Start} is displayed.

```
SD Card      →
>Prepare     →
  Temperature →
  Motions     →
```



```
Preheat
Load Filament
>Unload Filament
```



```
*Temp : ↓134/240°
Wait...
```



```
Temp : ↓240/240°
>Unload Start
```

- ③ When you select **{Unload Start}**, the extruder motor to move the filament is operated to pull up the filament inside the extruder. Wait until the filament is automatically pulled up.

After a while, "Pull Out Filament" will be displayed on the LCD screen. **Pull out the filament (2) while the filament handle is pressed(1).**

Unloading...  
Wait...



Unloading...  
Pull Out Filament

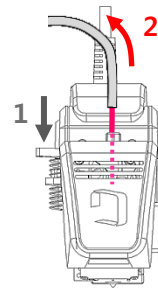

- ④ Press the **[ENTER]** button to terminate unloading.



\* **Make sure that no part of the body contacts the nozzle area, as both the nozzle and the filament are hot when the extruder nozzle temperature is raised.**  
 \* **Always press the filament handle when you pull out the filament.**  
**This is to prevent the problem that result when the edge of the melted filament is stuck inside the extruder.**



**When unloading the filament, it can be stuck into the extruder due to the different end shape depending on the filament type.**  
**Do not force to pull out the filament during unloading in case the filament is stuck in or it may cause the blockage. Unload the filament after pushing it into the nozzle to melt its end and making the end shape.**  
**When using Unloading menu, it will load the filament to shape the end of filament and unload it.**  
**If you are forced to pull out the filament and it is stuck inside of the extruder as residuals, you should repair the module Extruder.**

## 6.7. Separating Extruder module (Mounting)



**An electric shock can damage the printer if the detachable extruder is separated or mounted while the power is [ON].**  
**Separate or mount the detachable Extruder when the power is off.**

You can easily separate extruder module from the printer body by unfastening the screws and Extruder cable.

If there is some problem on the extruder module, use can remove the module from the printer body and ask AS request with ease.

If it is somehow difficult to detach the extruder module, do not forcibly remove the module, require the AS with the whole printer unit.

The mounting should be done in reverse order of separating process.

- ① To separate the extruder module, pull out the Teflon tube inserted into the filament entry of the extruder and **run unloading to remove the filament inside the extruder.**

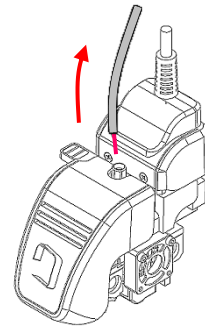

**It should be noted that separating the detachable extruder part while the filament is inserted into the extruder can damage the sensor or the equipment.**  
**If unloading is not possible because of a printer problem, etc., cut off the filament at the filament entry of the extruder and carefully separate the detachable extruder by pressing the filament handle.**

- ② Turn **[OFF](O)** the printer.  
 An electric shock can damage the printer if the detachable extruder is separated while the power is **[ON]**.



- ③ Unfasten two cable fixing screws by turning it counterclockwise using a 2mm Wrench (1), remove the extruder cable fixing block (2), and pull out the extruder cable from the extruder module (3).  
**If you use excessive force to remove the cable connector and cable, it will be damaged as the table is the locking Type Connector. Please press the locking to unlock and pull out the extruder cable.**

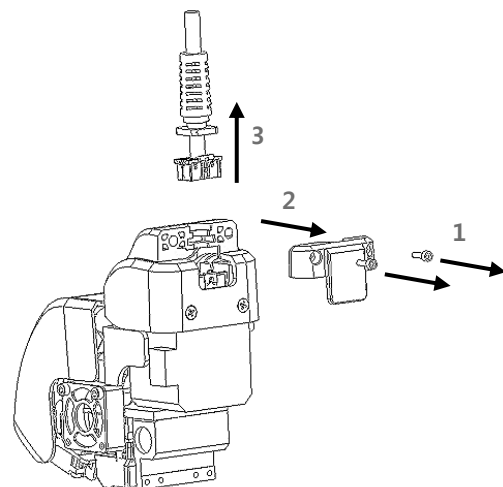

- ④ Open the Extruder cover(1), unscrew the internal extruder module fixing screw(2) and close the extruder cover(3).

Keep the parts such as Cable fixing screw, Extruder module fixing screw, and fixing block for reuse when assembling the module.

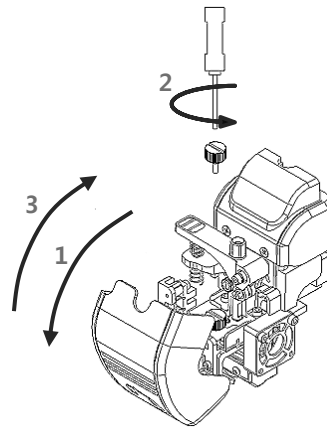

- ⑤ Push the extruder module to the right side to disassemble it from the extruder bottom fixture(1) and lift it up(2).

Please be careful not to be damaged by pole of printer body or belts.

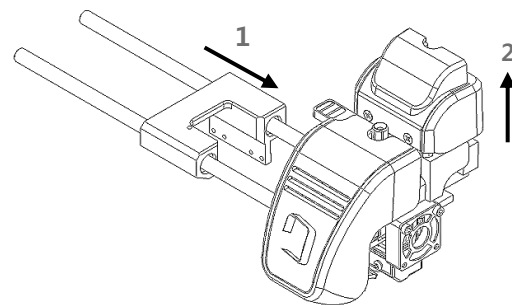

Periodically open the extruder cover and clean inside of the extruder.



- \* When opening the extruder cover, ensure there is no printed object on the build plate. The opening cover may cause the bump against the printed object.
  - \* Be careful not to be damage the internal wiring of extruder. If wire is damaged, it may cause the malfunction.
  - \* **Separate or mount the extruder module only when the printer is turned off and the extruder nozzle is sufficiently cooled.**
  - \* **Be careful to avoid being burnt if you have to separate or mount the extruder module when the nozzle temperature is high.**
  - \* Be careful when you separate or mount extruder module, as the excessive force can damage the extruder parts.
  - \* **If you print a model while the extruder module is not properly mounted or the screw is not tightened, the extruder may malfunction during printing, resulting in a printer error or malfunction.**
- Make sure that the extruder module is properly mounted before printing.
- \* As the extruder unit contains electrical parts, do not touch it with wet hands in order to avoid electrical shock.

## 6.8. Cleaning Printer



- \* Each printer is packaged only after it has been tested.
- For this reason, there may be some traces of usage on the heating bed, extruder, nozzle, etc. when you open the package. You can be assured that this is due to testing.
- \* When you clean the printer, turn it off first if possible.

### 6.8.1. Cleaning for normal Auto Leveling

Auto leveling process of Cubicon Style is that the top of the nozzle touches the leveling point of heated bed to check the current flow, the distance between heated bed and nozzle is recognized and automatically calibrates the bed leveling. If there is no current flow due to the dirt on the bed and nozzle, Auto leveling may fails. For the successful leveling, clean the contaminant and do Auto leveling process.

#### a. Removing the contaminant of leveling point of heated bed

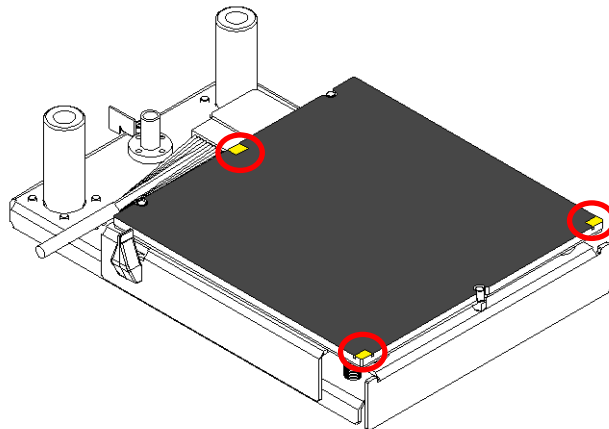

The highlighted red circles at the above figure are uncoated leveling points for Auto Leveling. The leveling points of heated bed may be contaminated by the molten filament while Auto Leveling process. If the contaminant remains without cleaning it, Auto Leveling fails due to sticking to the bed. Before printing, clean the bed through tweezers and scraper. Also, nozzle cleaning brush is built in at the left behind of heated bed, which it is made of heat-resisting rubber to clean the top of nozzle. If the nozzle cleaning brush has residues, please remove it so as not to cause the secondary pollution of nozzle tip. Please contact the authorized AS Center to find out the consumable nozzle cleaning brush.

#### b. Removing the contaminant of nozzle tip

Even though the leveling points of heated bed are clean, the contaminant of nozzle tip may prevent the current flow causing failure of leveling. Heat the nozzle to a level high enough to the using filament and wipe out the pollutant of nozzle tip using a rag. In case of considerable carbonized pollutant, wipe out the nozzle tip with a rag (Slightly dust off through steel brush).



- \* When you clean the printer while the nozzle is heated, be careful with the hot nozzle.
- \* It should be noted that the nozzle can be damaged and the print quality deteriorated when you press the nozzle hole with tweezers, etc.



### 6.8.2. Cleaning of Heated Bed

The heated bed is the bottom on which the printed object is formed through the extrusion of the melted filament. It can easily become dirty due to melted filament or filament fragments, and when printing is continued in this condition, the dirt may adhere to the printed object, damaging the object, or the printed object may not adhere to the heated bed during printing.

The heated bed must be cleaned before and after printing to prevent defective printing due to dirt.

- ① Filament residue on the heated bed can be removed using tweezers, a scraper or a brush. Make sure that the surface of the heated bed is not scratched. If the surface is scratched, the coating can be removed, and the printed object will not adhere to the heating bed.
- ② Filament stuck on the heated bed surface during printing or residual left after printing may not be easily removed. For this type of cleaning, use concentrated acetone to wipe out the pollutants.  
**Use another wet towel to completely remove the acetone from the bed's surface before using the printer again.**

\* Please use the high purity acetone and water.

	<ul style="list-style-type: none"> <li>* The heated bed may look stained, but it this is natural due to the coating, and there is no problem with using the heated bed for printing.</li> <li>* The life of the coating on the heated bed depends on the printing habits of the user. If the printed output comes off the heated bed too easily, replace the heating bed.</li> <li>* The heated bed of Cubicon Style does not require the Kapton tape when using the ABS/PLA certified with Cubicon Style under appropriate temperature conditions. You can often get better printing results when you use tapes based on user's personal printing habit or according to types of printed model, in which case, please make sure you use heat resistant and 3d printer specific tapes. In case of using normal generic tape, you may get in trouble of replacing the whole bed due to the glue remaining on the bed.</li> </ul>
	<p>For a printer using the melted filament, contraction can occur due to the hardening of melted filament. This may cause the printed object to come off the bottom. Although the problem can be corrected by changing the print temperature condition, heated bed adhesion or slicing option, the problem is basically generated by the material, which contracts when it is cooled and hardened. <b>To solve the problem, consider using a design that distributes the contractile force during the design of 3D model.</b></p>
	<ul style="list-style-type: none"> <li>* <b>Do not use a solvent other than the water and acetone on the heating bed. This may damage the coating.</b></li> <li>* <b>When you use acetone to clean the heating bed, make sure that no part other than the heated bed is stained with the acetone. It may damage the product.</b></li> <li>* <b>When using acetone, make sure there is sufficient ventilation and use it with caution. (Strictly follow the safety rules provided on the acetone package.)</b></li> <li>* <b>Do not disassemble the heated bed or apply excessive force to remove the printed object. The impact can cause a problem.</b></li> </ul>

### 6.8.3. Cleaning of Extruder

The extruder nozzle is positioned at the bottom of the extruder module, and pushes out the melted filament to form the printed object.

After extended use, the printing condition may become poor due to filament residue or external pollutants, and in severe cases the nozzle may even become plugged, requiring the replacement of the nozzle.

You need to clean the nozzle regularly to use it for an extended period of time.

#### a. Maintaining the Nozzle in Clean Condition for a Long term period

If a nozzle becomes plugged, it is likely to continue causing problems until it is replaced. As it is possible to keep a nozzle clean for a long time through good management, take note of the following tips

- ① Check the nozzle's condition regularly and clean it.
- ② If the filament discharge condition is anomalous, such as the filament coming out of the nozzle during printing being too thin or not uniform, stop printing and clean the nozzle. This should be performed immediately, as a pollutant inside the nozzle can deteriorate the nozzle's condition at any time.
- ③ Sufficiently clean the nozzle if possible when the filament is replaced. **In particular, the nozzle must be cleaned when a different type of filament with different printing temperature condition is being replaced**, such as ABS or PLA.

It is recommended that the detachable extruder part specific to the filament be used when a filament with a different printing temperature is used.

- ④ Generally, a filament pollutes the nozzle more severely if it has a color (incl. white) or has a darker color. Clean the nozzle more often when you use such filaments.
- ⑤ A filament will have properties that are different from its initial properties if it has been melted once and hardened. In other words, if heating/cooling is repeated without the filament inside the nozzle being discharged, the filament will become the pollutant, and will not be able to be used for printing. Therefore, make sure that the heating/cooling is not repeated without the filament nozzle being discharged.
- ⑥ The filament will begin to be polluted by moisture and dust as soon as it is removed from the vacuum pack. Start using the filament as soon as possible after it is opened, as the nozzle will become plugged when an excess of pollutants is accumulated.

#### b. Cleaning Inside Nozzle through Loading process

- ① Pull out the filament sufficiently by selecting **{Prepare > Load Filament}** from the functional menu. Loading will stop automatically after a certain amount of filament is discharged if the user does not stop it.

Set the temperature of load filament to be the same as the filament temperature.

- ② If the print condition is not satisfactory after step ①, set the temperature of Load Filament to a higher temperature than the filament temperature and repeat step ①.



- \* **Do not raise the temperature more than 10% higher than the normal filament discharge temperature. This may change the filament property and intensify nozzle plugging.**
- \* **Do not perform "step b" if the filament does not come out of the nozzle or is too thin. This may split the filament or twist the filament inside the fixed extruder part and cause a problem.**

### **c. Cleaning Inside the Nozzle Using Nozzle Management Pin**

If you cannot improve the printing quality with loading or cannot load the filament, it is likely that residue has been left in the nozzle or that nozzle hole plugging is too severe for the pollutant to be removed by loading only. In that case, clean inside the nozzle with the enclosed nozzle management pin, in consideration of following:

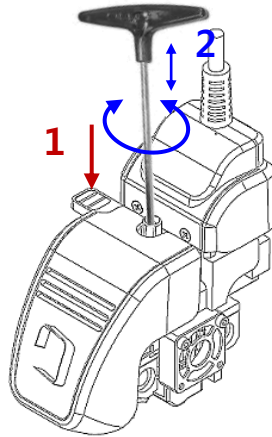

- ① Remove the remaining filament inside the Extruder through Unloading process.
- ② Heat the extruder (nozzle) to a temperature that is not more than 10% higher than the discharge temperature of the filament remaining inside the nozzle.  
This is to sufficiently melt the remaining filament inside the extruder, pay attention not to heat up the temperature of extruder nozzle which the filament may be carbonized and block the nozzle.
- ③ While pressed the filament handle (1), insert the nozzle management pin into the filament insertion hole (2), and slowly move it back and force to push the residue out of the nozzle. It will be easy to clean the nozzle considering the distance from filament insertion entry to the top of nozzle.
- ④ When the impurities inside the nozzle are removed, wait a while at high temperature and repeat the removal of the impurities(STEP 3). This step is to remove the impurities after waiting for the impurities stuck on the inner wall of the nozzle to be melted and lid down.
- ⑤ Load or unload the filament in use to melt the filament inside the nozzle, and repeat the steps beginning with ①. This is to remove the impurities by dissolving them into the melted filament.

The figure on the right shows the discharged filament after loading to remove the impurities inside the nozzle. It clearly shows the filament polluted with impurities at the edge. Remove the impurities inside the nozzle sufficiently until the point at which the filament does not show the pollution any longer.



Since the pollution inside the nozzle is usually detected when the nozzle is plugged during printing despite being normal when the printing began, proper management of the nozzle is needed.

If the filament is discharged (pushed down to the bottom) from the nozzle or the print quality is poor, it is likely that the nozzle has been damaged. In this case, replace the nozzle. Make sure the nozzle is replaced by an authorized service technician.



#### **d. Cautions When Using Nozzle Management Pin**

Proper use of the nozzle management pin can greatly help nozzle management.

However, as the nozzle management pin moves along the path of the filament's movement inside the extruder, improper use of the nozzle management pin can cause damage or pollution to the extruder inside, which can create severe problems for the extruder. As an extruder problem caused by the improper use of the nozzle management pin is considered to be damage caused by the user, it will not be covered by the warranty.

##### **① Plugging of Nozzle by Damaged Part**

Using the nozzle management pin with excessive force will damage the part on the moving path or scratch the part, causing fragments to fall inside the nozzle and plug the nozzle. This will make it very difficult to unplug the nozzle, and the whole nozzle rod may have to be replaced. For this reason, you should be careful not to damage the parts.

##### **② Secondary Pollution by Filament Residue Stuck on the Nozzle Management Pin**

When the nozzle management pin is used, the melted filament residue will be stuck at the edge of the nozzle management pin. If you pull out the nozzle management pin while the filament residue is not sufficiently cooled, the filament residue may be stuck in the entry of the nozzle rod or on the parts in the path of filament movement inside the extruder, preventing the nozzle management pin or filament from moving.



- \* When disassembling the extruder module while the nozzle is hot, wear gloves to avoid burns.
  - \* Use the nozzle management pin with extreme caution until you are familiar with it.
- As improper use of the nozzle management pin can damage the extruder part beyond repair, it is recommended not to use it if you are not familiar with its use.

#### **e. Cleaning Outside Nozzle**

The nozzle is at a high temperature during printing, and often has melted filament residue stuck on its surface. Filament stuck on the nozzle surface can adhere to the printed object during printing, creating stains.



- ① Heat the nozzle to a level high enough to melt the filament stuck on the surface. Then, remove the filament residue with the tweezers or wipe it out with a rag.
- ② If the pollution on the nozzle's surface is severe, cool the nozzle completely and turn off the printer. Wipe out the pollutant using a rag with a small amount of acetone. Use the printer only after the acetone is completely vaporized.
- ③ During the loading or auto title process before printing, some filament is taken out through the nozzle to form the printed object with clean filament. Remove any residues on the nozzle before printing, as they can affect the printed object



- \* When you clean the printer while the nozzle is heated, be careful with the hot nozzle.
- \* It should be noted that the nozzle can be damaged and the print quality deteriorated when you press the nozzle hole with tweezers, etc.
- \* If you use acetone for cleaning the nozzle, be careful not to stain parts other than the metallic nozzle with acetone. This may damage the product.
- \* When using the acetone, make sure there is sufficient ventilation and use it with caution. (Strictly follow the safety rules stated on the acetone package.)

#### 6.8.4. Replacement of Clean Filter

To filter the pollutants generated by the FFF type printer, Cubicon Single uses a clean filter organized into three filter layers: Purafil catalyst, HEPA filter and deodorizing filter.

If the clean filter unit contains too many pollutants, it not only will degrade the filter's performance but will also interfere with the operation of the filter fan, causing problems. If the pollution of the clean filter is too severe, do not clean the filter but replace it.

Although the clean filter replacement interval differs according to the printing environment and user printing habits, it is recommended to replace it every 6 months.



**The clean filter should be installed in the correct direction in the case. If the direction is not correct, the filter's performance will deteriorate, and it will cause a ventilation fan problem.**

#### 6.9. Firmware Update

Connect the PC with the printer using a USB cable. Download the latest firmware file.

To improve the stability, the Cubicon Style applies the switch at the right bottom of the machine.



Before the firmware update, move the switch to ▼ position as highlighted in red at the above picture.

After the firmware update is completed, move the switch to | position.

For more details on how to update the Firmware please refer to the Cubicreator user manual.



**Please use our provided Firmware (Cubicon Style) when the Firmware Update.  
If you update through other machine Firmware data, it may cause the damage on the machine and the safety issue.  
Please make sure if the selected Firmware is compatible with the Cubicon Style (3DP-210F).**





## 7. Printing

This chapter describes several important scenarios of actual printing using the SD memory card after the printer is installed.

(Refer to the Cubicreator Software Operation Manual for the details of printing using a USB connection to a PC.)

### 7.1. Printing for the First Time

After the printer is installed, print a sample as shown below to check the condition of the printer.

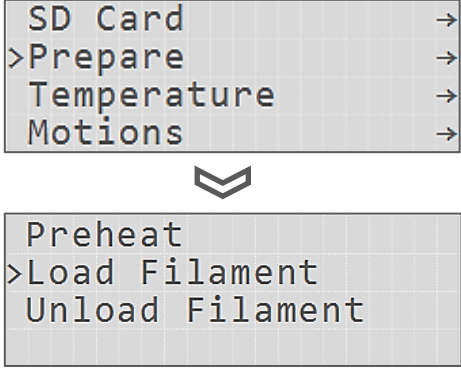
	<p><b>Before turning on the printer, confirm that all packing materials inside the printer have been removed, the cables and parts are not damaged, the bed and extruder are properly installed, and the spool mounting/rotation direction/rotation condition are normal. If there is any problem, correct it first before turning on the printer.</b></p>
<p>① Mount the filament spool in the spool carrier of the printer and push the filament all the way to the entry of the Teflon tube inside the printer.</p> 	<p>② Turn <b>[ON]</b> the printer.</p>  <p>* Number on the display changes according to the surrounding temp.</p>
	<p><b>When switching power on, the machine automatically check the main parts relevant to the heating.</b>  <b>If you can see the message "Check SelfTestResult" instead of "Cubicon Ready", there is someproblem on the main parts, therefore stop operating the printer and go to the {Configuration&gt;SelfTest Result} menu to find out the part indicated as "FAIL".</b>  <b>In case of difficulty on the self-maintenance, please contact the authorized AS Center.</b></p>
<p>③ Press the <b>[OK]</b> button of the display and select the <b>{Prepare &gt; Load Filament}</b> menu.</p>	

- ④ Select {Temp} in {Load Filament} and turn the [ENTER] button to **set the temperature to 240°C and heat the nozzle.**

```
*Temp : ↓234/240°
Wait...
```



When the extruder nozzle temperature reaches the target temperature, the "Wait..." message will disappear and the {Load Start} menu will be displayed.

```
Temp : ↓240/240°
>Load Start
```



When you select {Load Start}, the "Wait..." message flickers and the extruder motor to move the filament is operated.

```
Loading...
Wait...
```



When the movement of Extruder is stopped, , Insert the filament into the filament entry of the extruder. When you push it approximately 3cm into the entry, it is notched and automatically pushed down. Manually push it until it is notched.



When some amount of melted filament is pushed out of the nozzle, press the [OK] button to stop filament loading.

```
Loading...
Touch OK Button
To Load Stop
```

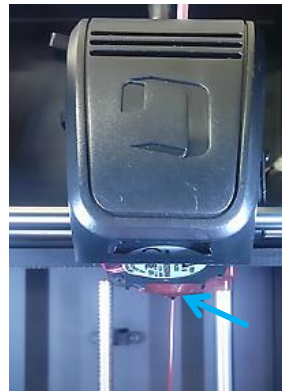

Do not worry if the color of the melted filament that comes out of the nozzle during loading is different from the loaded filament. It is filament that was used during the test and left in the nozzle.

Please remove the dirt on the level point of the heated bed plate.



- \* It is recommended to set the nozzle temperature during the very first printing as the ABS temperature, regardless of the type of loaded filament, if ABS or PLA is used. It is set to 240°C for the final print quality test. During the test, the ABS load temperature is used to support both ABS and PLA filaments. (Refer to "[6.5. Cautions and Notes](#)", "[7.2. Printing after Replacing Filament](#)")
- \* If the type of filament used in previous printing is not clear, set the extruder nozzle temperature based on the filament of higher temperature, and heat the nozzle.
- \* When replacing the filament, it is recommended to load the filament so that a sufficient amount of filament is pushed out of the nozzle (1m or longer).

- ⑤ Insert the enclosed SD card in the SD memory reader and select the file to be printed. Press the **[OK]** button and select **{SD Card}** from the functional menu on the LCD screen. Select a G-Code file (\*.hvs) from the list in the SD card.

Select an "ABS\_\*.hvs" file if the loaded filament is ABS, and a "PLA\_\*.hvs" file if it is PLA. Only files with the .hvs extension can be used for printing.

The enclosed SD card contains the G-Code (\*.hvs) files of the models with small printing time for sample print.



```
>Print SD File
Just Print.hvs
Your Style.hvs
with Cubicon.hvs
```

- ⑥ When the heating bed temperature and extruder nozzle temperature are raised to the target temperatures recorded in G-Code, auto leveling of the heating bed is automatically executed, and printing begins.

**The entire process is executed automatically when the user selects a G-Code file to be printed.**

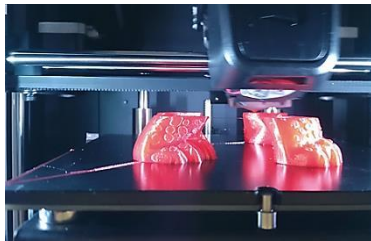

- ⑦ When printing is complete, **do not forcibly remove the printed material from the heating bed, but wait until the heating bed is cooled down.** You can easily remove the printed object from the heating bed when the heating bed temperature is cooled down to room temperature.

If the printed object is not removed from the heating bed even after the heating bed is cooled, create a small space at the edge of the bottom of the printed object with a flat object, and the object will be easily removed.



- \* **ABS and PLA have different print temperatures (extruder and heating bed). The temperature condition must be reflected in the G-Code file (\*.hvs for Cubicon) when the file is created.**  
A sample G-Code file is included in the SD card for novice users.  
To print a 3D model, a user can create a G-Code file (\*.hvs) of the 3D model using the latest Cubicreator slicing program included in the enclosed SD card or downloaded from the Cubicon homepage, then print the file.
- \* **The printing condition differs according to the filament type (ABS or PLA) and according to the color even for the same type. In extreme cases, the condition may differ according to the filament manufacturing lot. As well, you can improve the print quality by fine-tuning the print condition according to the 3D model. To obtain the best print quality, it is important to find the optimum condition of the filament according to the model.**



- \* **The printing temperature condition of the extruder and heating bed must be the same as the filament temperature. If not, the print quality may deteriorate, and in extreme cases may cause extruder problems.**  
**Check the print temperature condition of the printer and filament in use before printing.**  
**If the temperature condition in the G-Code file differs from the filament temperature condition, you can change the temperature condition by selecting {Temperature > Extruder / Bed} from the functional menu.**
- \* **If you use excessive force to remove the printed object from the heating bed after printing, it may cause dislocation of the heating bed or electric shock and damage the printer. Wait until the temperature of the heating bed falls to room temperature.**

## 7.2. Printing after Replacing Filament

As described in “[6.6. Replacing Filament](#)”, it is the process of unloading a previous filament (A) and loading a new filament (B) to use other sort of filament.

The process can be divided into the following steps:

- 1) Unload the old filament (A) (Remove the filament(A) from the extruder)  
 {Prepare>Unload Filament} → **Nozzle heating temperature (UT)** → “Unload Start” → “Pull Out Filament” → {Unloading Stop}.
- 2) Remove the old filament(A) from the filament carrier and mount the new filament(B).
- 3) Load new filament(B) (Insert the new filament(B) into the extruder, melt it and push it out of the extruder nozzle)  
 {Prepare>Load Filament} → **Nozzle heating temperature(LT)** → “Load Start” → Loading Stop
- 4) Select the G-Code file created with the temperature condition of the new filament, and print.

Even experienced users often make mistakes when setting the nozzle heating temperature, i.e. the extruder nozzle temperature, during loading and unloading.

**During unloading, set the nozzle heating temperature (UT) to pull out the existing filament (A). During loading, set the temperature to insert the new filament (B) into the extruder and discharge it,** as well as the nozzle heating temperature (LT) to remove the filament (A) that is already melted in the nozzle. It is important to load a sufficient amount of new filament (B) and discharge it in order to remove any filament remaining in the nozzle.

**This is the most important step in replacing a filament with a new filament.**

PLA is generally melted at a lower temperature than ABS. When replacing an ABS filament with a PLA filament, if the nozzle heating temperature during loading (LT) is set to the PLA temperature, the ABS filament inside the nozzle will not melt, and thus will remain as residue, plugging the nozzle.

When replacing a PLA filament with an ABS filament, the PLA filament remaining on the nozzle’s inner wall is sticky and cannot be easily removed. For this reason, a sufficient amount must be loaded to remove the PLA from the nozzle several times to avoid nozzle plugging.

The following table shows the nozzle heating temperatures (UT)/(LT) according to the filament type (A)/(B) when the filament (A) is replaced by the filament (B) given an ABS temperature (extruder temperature) of 240°C and a PLA temperature of 210°C.

Remark	(A) ABS → (B) ABS	(A) ABS → (B) PLA	(A) PLA → (B) ABS	(A) PLA → (B) PLA
Unloading Nozzle Heating Temperature (UT)	240	240	210	210
Loading Nozzle Heating Temperature (LT)	<b>240</b>	<b>240</b>	<b>240</b>	<b>210</b>

The values in the table are just examples, and are not absolute values. The users must set the optimum condition based on their experience.

### 7.3. Replacing Filament during Printing





There may be the need to replace the filament during 3D printing because the filament in use has run out or the user needs to use another filament.

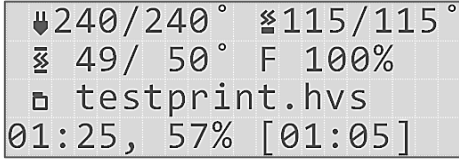
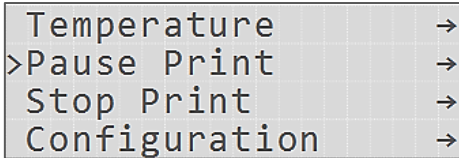

To support this, Cubicon Style has a function that enables the user to suspend printing, replace the filament and then resume printing.

This process is described below.

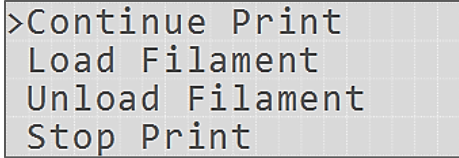
Press the **[OK]** button during printing to display the functional menu.

As described in “[6.4. Functional Menu during Printing](#)” a different functional menu is displayed when the **[OK]** button is pressed during printing.

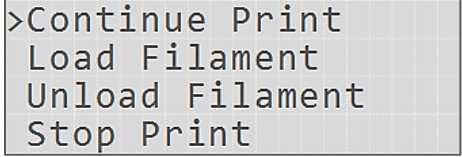
<p>① The figure on the right shows that printing is in progress.</p> <p>To pause printing, press <b>[OK]</b> to display the functional menu and select <b>{Pause Print}</b>. The menu structure differs from print standby mode.</p>	 <p style="text-align: center;">⌵</p> 
<p> <b>The menu function can be accessed using the [OK], [UP], [DOWN], and [BACK] buttons.</b></p>	
<p>② Select <b>{Pause Print}</b> and wait for a while. Printing is suspended, and the menu shown in the figure is displayed.</p> <p>The extruder of the printer moves to the standby position (rear center) and is fixed.</p> <p>Printing is not stopped immediately, but after the data in the buffer memory is printed. The actual time will differ according to the 3D model.</p>	
<p> <b>If using Pause / Continue function during printing, the filament inside the nozzle flows out to contaminate the printed object or to change the print quality due to the difference of molding condition, we recommend not to use Pause except a special case, and please ensure the sufficient filament is fed into the printer before printing.</b></p>	
<p> <b>When printing is paused, the extruder moves to the standby position and remains fixed there. Being fixed means that the extruder is locked so that the X/Y/Z movement motor is not operated. If the user manually moves the X/Y (extruder) and Z (heating bed) position, the printing position can be incorrect when printing is resumed and cause the printer to malfunction. Never change the extruder and heating bed positions when the movement motor is locked.</b></p>	
<p>③ Proceed with following steps.</p> <p>{Unload Filament} → Nozzle heating → “Pull Out Filament” → {Unloading Stop} → [BACK] → Replacing the filament spool in the spool carrier and inserting the filament all the way to the edge of the Teflon tube in the printer main body → {Load Filament} → Nozzle heating → “Input Filament” → {Loading Stop} → [BACK]</p>	

	<p>* The nozzle heating temperature during unloading is set to the nozzle heating temperature before printing was paused unless the user changes it. It can be changed in {Unload Filament&gt;Temp.}.</p> <p>* The nozzle heating temperature during loading is set to be the same as the nozzle heating temperature during unloading. It can be changed in {Load Filament&gt;Temp.}. The nozzle heating temperature during loading should be set in consideration of both existing and new filaments.</p>
<p>④ After replacing the filament, select the {Continue Print} menu and resume printing.</p> <p>The extruder and heating bed of the printer return to the position before the pause, and printing is resumed.</p>	
	<p>When {Continue Print} is selected, the extruder unit moves to the printer home position, which is left forward, pushes out some filament to maintain a clean discharge, and then moves to the print continuing position. You can easily remove the filament at the edge of the nozzle during loading.</p>

## 7.4. Supplying Filament after Filament Runs Out during Printing

The gear connected to the Extruder motor moves the filament downward.

If the filament is stuck in gear, it can be removed through Unloading process.

However, when the filament is used up, there is the remaining filament inside which cannot be pulled out from gear of the Extruder to the top of the nozzle.

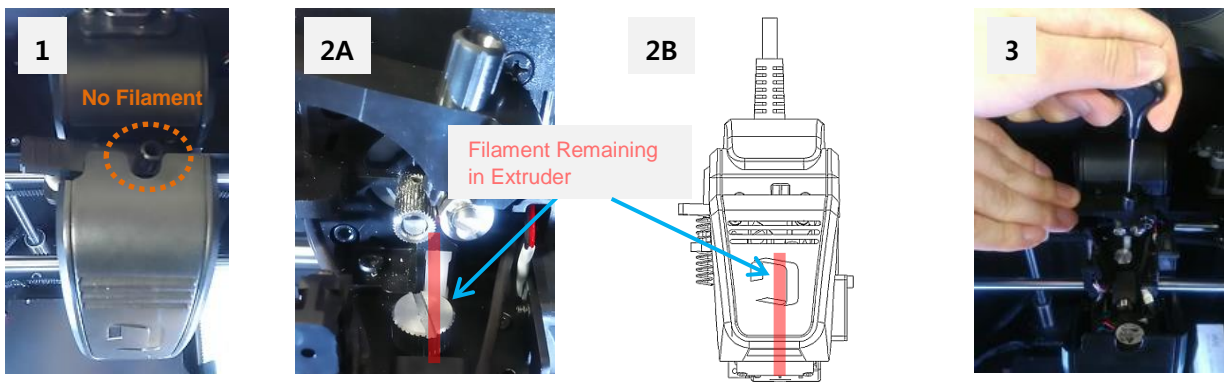

The above picture shows the scenario in which filament runs out during printing.

Although the filament is not visible from outside, as shown in the picture (1), the filament fragment actually remains inside the extruder, as shown in the figure (2A) and (2B).

**If you insert a new filament without removing the filament fragments remaining in the extruder, the new filament will not be pushed out of the nozzle and can cause a problem with the extruder. For this reason, you must unload the existing filament.**

The remaining filament under the Extruder gear should be pulled out of the nozzle by inserting nozzle management pin when the nozzle temperature is heated up at the proper temperature, as





shown in the figure(3).

Otherwise, push in the solid filament such as ABS/PLA through loading process(manually or automatically) and **continue to print after checking the extrusion of the remaining filament through nozzle.**

For more details on loading and unloading, refer to "[6.6. Replacing Filament](#)" and "[7.3. Replacing Filament during Printing](#)".

## 8. Troubleshooting

	<p>* Problems with the printer hardware can sometimes be solved by initializing the printer through {Configuration &gt; Initialize EEPROM} in the functional menu or by updating the firmware. Please refer to the Cubicreator Operation Manual for information on updating the firmware.</p> <p>* In some models, the print quality can depend greatly on the print condition or the Cubicreator option setting during G-Code creation. For this reason, you should attempt different print conditions or option settings to find the optimum print quality.</p>
	<p><b>When the printer has the problem, it is important to make sure the issue clearly. If nessary, please send the picture or video to the CS Center.</b></p>

### 1) I cannot see the data on the SD card.

- Confirm that the SD card is properly inserted into the SD card reader.  
Confirm that it is oriented in the correct direction, and insert it again.
- The SD card may have been damaged. Use another card and check.
- Cubicon Style support the SD card formatted in FAT 32 File system.  
In case of the SD Card with different file system, please format to FAT32.  
It may not support FAT32 according to the SD Card.
- Cubicon Single supports files with file names that use alphabet characters only. If you use another language for the file name, the name may be corrupted or empty. Change the file name to use alphabet characters only and try again.
- Only file of \*.hvs extension can be displayed on the LCD display. Please make sure if the \*.hvs File is stored in SD Card.
- The number of Files in the SD Card is limited up to 150 per each folder. Clean up the folder because it is not shown if there are more than 150 files in the folder.
- Folder of the SD Card will be recognized up to step# 2 Sub- folder.  
In other words, it is recognized as Root / Sub1 / Sub2.

### 2) The data in the SD card is not output.

- Confirm that the file to be printed is a G-Code format file with the \*.hvs extension.  
Cubicon Single can use only G-Code files (with the \*.hvs extension) format that have been sliced with Cubicreator. G-Code files created using other slicing programs may not be supported.
- Please make sure if it is set as "**Cubicon Style (3DP-210F)**" in Cubicreator. It may cause the printing error when it is set as other machine.
- The data in the SD card may be damaged. Create the G-Code file again and try it.
- If you set the wrong option on the Cubicreator when slicing it cannot be printed well. Use the

Cubicreator to make sure that G-Code file is normal. If the print path which seems G-code appears to be an unusual path, G-Code is incorrect.

- The slicing through the Cubicreator cannot work well due to the wrong 3D Model. Open the original 3d model through the Cubicreator, check if there is any problem on slicing or G-Code conversion 3D and determine whether the 3D model is ok using other 3D model inspection program.
- Data may have been incorrectly saved in the SD card because of a security program or a virus. Check the data, make the necessary correction and try again.

### 3) I cannot print with the PC connection.

- Check to determine if there is any problem with the PC to printer connection via USB.
- Check whether the Cubicon Style driver is installed in the PC. Install it if needed..
- Please make sure if it is set as “Cubicon Style (3DP-210F)” in Cubicreator. It may cause the printing error when it is set as other machine.
- Confirm that the OS of the PC is supported by Cubicon.  
If it is OSX(MAC OS), you should use more than the Cubicreator v2 for OSX, Baudarate of printer should be set as 115,200
- Please make sure if the Firmware Update switch is correctly located. (Refer to [“6.9. Firmware Update”](#))  
The switch should be located in normal position when Firmware Update and normal printing process.
- Check to determine whether the PC has been infected by a virus. Correct the problem and reinstall the driver.

### 4) The filament is discharged out of the nozzle.

- Ensure that the filament is authentic.  
Because some filament has the different temperature condition to the authorized filament or thermal deformation it may cause the problem when extruding filament and therefore the Extruder can be broken down. The failure of printer by using the unauthorized filament is excluded from the warranty service.
- Please make sure if temperature condition is properly set according to the filament. If the material with low extrusion temp such as PLA is set at the high temperature like ABS, it may cause the considerable transformation due to high temperature of heated bed and nozzle causing slow movement inside of the extruder. Please make sure proper temperature condition according to the filament.
- In case the filament is twisted or jammed inside of the Extruder, it may cause the problem on the extruding to stop extruding the filament.  
The twist problem may be improved with decreasing the temperature of inside of the equipment.
- Confirm that the filament is seamlessly supplied. If the filament in the spool is twisted or bent, correct the problem.  
Twisted or wound filament may be cause the continuous problem, so it is recommended to discard it.
- Contaminated Filament by humidity or dirt can be changed from the first opening.  
Using this filament cause the malfunction such as blockage of the Extruder. Please use the

opened filament as fast as possible, secure the filament to the spool not to be wound and keep it in the vinyl for a short period to prevent the humidity/dirt.

→ Make sure the thickness of supplied filament is too thick or thin. Please use the 1.6~1.9mm diameter of filament for the accurate supply.

Using thin or thick filament may cause the malfunction such as getting jammed to the equipment.

→ Confirm that the extruder module and extruder cable are properly mounted.

→ Confirm that the temperature conditions of the filament in use and extruder of the printer are correct.

→ The nozzle may have been plugged. Clean the nozzle, referring to "[6.8.3. Cleaning of Extruder](#)".

→ Have the nozzle replaced by an authorized service technician. The nozzle is consumables.

#### 5) The printed object does not adhere to the bottom (heating bed).

→ Confirm that the filament is authentic. It may cause the malfunction of printer while printing because some filament is not stick to the heated bed.

→ Contaminated Filament by humidity or dirt can be changed from the first opening.

Using this filament cause the malfunction such as blockage of the Extruder. Please use the opened filament as fast as possible, secure the filament to the spool not to be wound and keep it in the vinyl for a short period to prevent the humidity/dirt.

→ Remove the pollutant from the heating bed.

Do not use wet wipes because washing ingredient of some wet wipes can contaminate the coating of heated bed..

→ Please check the Functional Menu {Configuration > Auto Leveling > OFFSET} value and set it "0". Do not change the offset value except for special purpose.

→ Confirm that the temperature conditions of the filament in use, heating bed and extruder are correct. In Cubicon Single, the heating bed and filament in use must have the proper temperatures to adhere well to each other.

→ Check whether the area stuck to the heating bed is too small, or the bottom of the printed object is irregular. You can correct the problem by using the bottom aid option or by slowing down the first layer print speed when creating the G-Code.

→ Use the proper tape when needed. For some models or filament types, it may be helpful to use a separate tape such as Kapton tape on the heated bed.

→ Check whether the coating of the heated bed is damaged, or the heated bed is bent excessively. In that case, the heating bed must be replaced. Use an authorized service.

#### 6) Parts (mostly bottom boundaries) of the printed object are taken off the bottom

→ Follow the solution on #5 the printed object is not stuck to the bottom (heating bed).

→ The problem can be partially improved by changing options such as internal filling when creating the G-Code.

→ This is due to contraction of the material caused by the printer using the thermal melting method.

Adjust the printing condition (extruder, heating bed and printer inside temperatures) or use material that does not contract in this way. Although contraction may improve with some materials, this is a natural phenomenon that occurs as the melted filament is solidified. **The**

**most effective way to correct the problem is to modify the model to reduce the contraction.**

#### **7) The middle of the printed object is cracked.**

- This is caused by contraction of the material caused by the printer using the thermal melting method.  
Adjust the printing condition (extruder, heating bed and printer inside temperatures) or use a material that does not contract in this way. Although there may be less contraction with some materials, it is a natural phenomenon that occurs as the melted filament is solidified. **The most effective way to correct the problem is to modify the model to reduce the contraction.**
- The problem can be partially alleviated by changing options such as internal filling when creating the G-Code.

#### **8) I cannot remove the printed object from the bottom (heating bed).**

- Wait until the heating bed is sufficiently cooled. The heating bed can be damaged if you remove the printed object from the heating bed by force.  
In Cubicon Single, the printed object is stuck to the bottom during printing and can be easily removed when the heating bed is cooled after printing is completed. The temperature at which the printed object is removed depends on the type of filament being used and the model.
- If the printed object is not taken off even after the heating bed is sufficiently cooled (to room temperature), push a flat object into the bottom of the printed object to take it off.
- If the residues of the printed object remain fixed on the heating bed, the printed object may be stuck to the residue, and not taken off the bed. Always keep the heating bed surface clean.
- If you do not completely remove the acetone from the bed after using the acetone to clean the heating bed, the printed object may not come off the heating bed. After using the acetone, completely wipe it out with wet cloth.
- You must replace the heating bed if the coating of the heating bed is damaged. Use the authorized service.

#### **9) Printing is completed, but only parts of the model are printed. Other parts are not printed at all, or are incorrectly printed.**

- Refer to the “4) The filament is not extruded out of the nozzle” and take the proper action.
- Check the model and G-Code. If the model is improperly designed, there can be a problem with G-Code creation. Modify the model and try again.
- For some models or supports, the printed object can interfere with the support, causing printing problems. This problem can be corrected by changing the slicing method (adjustment of the printed object, change of direction, etc.).
- Some filament (like Flexible) ranges narrow nozzle temperature spectrum. In case of printing with that filament, slow down the print speed and adjust the nozzle temperature as the speed differs according to the print model.
- Remove the foreign substances from inside the nozzle. Clean the nozzle, referring to [“6.8.3. Cleaning the Extruder”](#).
- If the problem continues when there is no problem with the model, replace the nozzle. Use the

authorized service.

**10) Printing is terminated due to failed auto leveling without completion.**

- The printer executes auto leveling of the bed before beginning printing. If the auto leveling fails for whatever reason (after several automatic attempts), the message “Tiltalign Failed” is displayed and printing is stopped. As the problem can be solved by rebooting the printer, turn off the printer, wait for around 10 seconds, and turn on the printer again.
- Re operate auto leveling after removing the dirt on the leveling point of heated bed and top of the nozzle. If there is no current flow due to the dirt on the bed and nozzle, Auto leveling may fail.  
(Refer to [“6.8.1. Cleaning for normal Auto Leveling”](#))
- Make sure if the nozzle touches the leveling point of bed when Auto Leveling calibration. If it touches out of leveling point, remove the bed plate, remount it and do auto leveling process again. If the problem continues, please contact the authorized AS Center to adjust the bed location.
- In case the heated bed is installed at height deviation of right/left side of heated bed. Or the heated bed is incorrectly mounted. Then, remove the bed plate and do auto leveling after remounting it. If the problem continues, please contact the authorized AS Center.
- If the heated bed is considerably bent or there is no current flow at the leveling point of heated bed due to the contamination, the heated bed should be replaced. Please contact AS Center to replace the consumable heated bed.
- Check whether the vibration in the environment affects the printer during auto leveling. Auto leveling can fail if the vibration is transmitted to the printer.
- If the problem continues, replace the heated bed or have the authorized personnel check the printer. Use the authorized service.

**11) Printing is stopped before completion**

- Check the power supply
- Check the connection with the PC if the printer is connected to a PC.
- The printer executes auto leveling of the bed before beginning printing. If the auto leveling fails for whatever reason (after several automatic attempts), the message “Tiltalign Failed” is displayed and printing is stopped. As the problem can be solved by rebooting the printer, turn off the printer, wait for around 10 seconds, and turn on the printer again
- Check if there are any items indicated as “FAIL” on the functional menu {Configuration > SelfTest Result > Test Again}. If the some parts is self-tested and indicated as “FAIL”, the operating stops due to the safety. In case the self-test can be conducted by yourself, proceed the print.  
Otherwise, please contact authorized AS Center.
- If the problem continues, please send the picture or video to the CS Center.

## 9. Product Specifications

Dimension	
Product size	322 x 350 x 486 mm (WxDxH)
Product weight	~ 15 kg
Packaging box	490 x 405 x 555 mm (WxDxH)
Packaged weight (incl. main body and accessories)	~ 21 kg
Temperature	
Ambient operating temperature	15 - 35 °C
Storage temperature	0 - 35 °C
Electronics	
AC input	Free Volt 100~240V, 50/60Hz
Power supply	AC/DC Adapter 24V, 6.3A
Power consumption	~ 150W (Max)
Memory and communication	SD Card(FAT32), USB Cable
Software	
Supplied slicing software	Cubicreator v2.5+ for Windows <b>Select the product in the Cubicreator “Cubicon Style (3DP-210F)”.</b>
Input 3D design file format	.stl , .obj
Supported OS	Windows XP, Windows 7 +/- OSX (separated Version)
Printing	
Printing technology	FFF- Fused Filament Fabrication
Printed object size	150 x 150 x 150 mm (WxDxH)
Layer height setting	150~300microns, minimum 100um
Printed wall thickness	Optimal: 400+um with 0.4mm Nozzle
Filament diameter	1.75 mm
Filament type	ABS, PLA, Flexible Filament
Nozzle diameter	Basic 0.4 mm
XY position precision	6.25 um
Z position precision	1.25 um
Max. nozzle temperature	260 °C
Max. heating bed temperature	120 °C

- The specifications can be changed, without advance notice, when needed to improve the product.
- The Firmware is based on the Repetier Firmware supplied with GPL License.

### Information to the User

This equipment has been tested and found to comply with the limits for a Class A digital device, pursuant to part 15 of the FCC Rules. These limits are designed to provide reasonable protection against harmful interference when the equipment is operated in a commercial environment. This equipment generates, uses, and can radio frequency energy and, if not installed and used in accordance with the instruction manual, may cause harmful interference area is likely to cause harmful interference in which case the user will be required to correct the interference at his own expense.

### WARNING

Any changes or modifications not expressly by the manufacturer could void the user's authority to operate the equipment.